

Case Nos. 9, 11 & 13

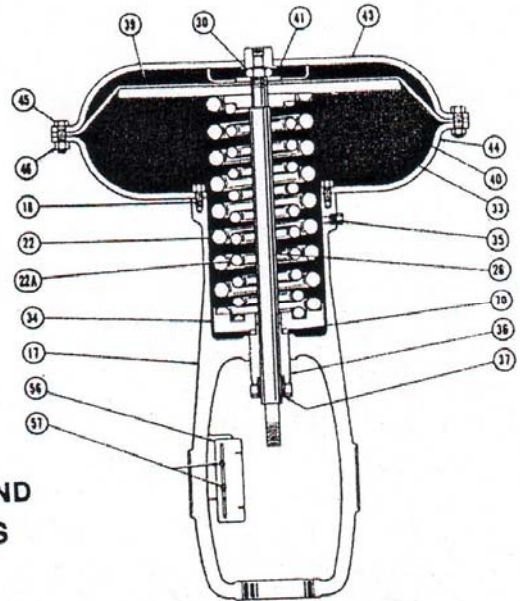

Case Nos. 15, 18 & 18L

AIR-TO-EXTEND ACTUATORS

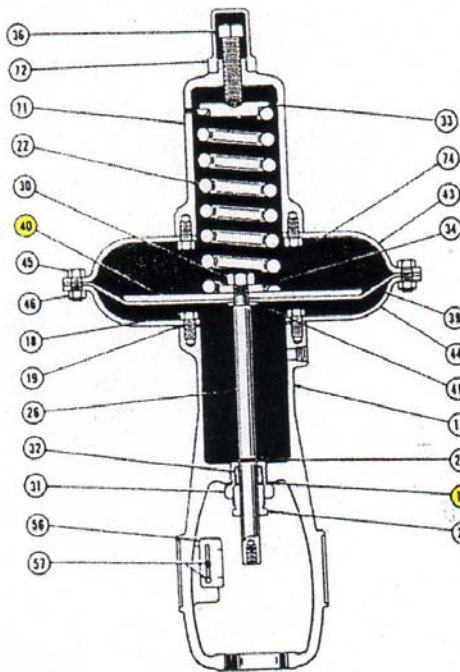

Case Nos. 9, 11, & 13

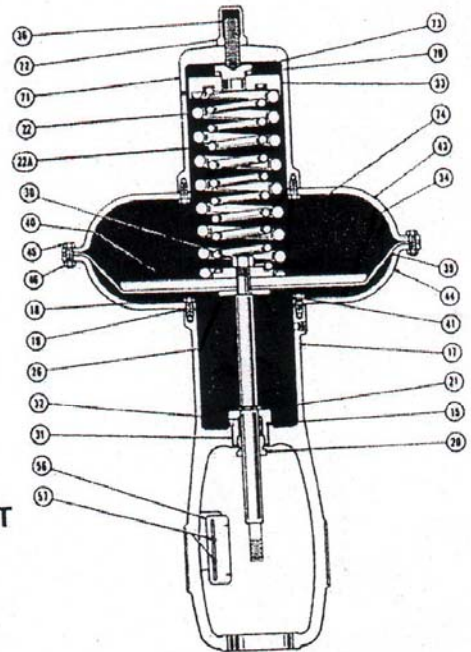

Case Nos. 15, 18 & 18L

AIR-TO-RETRACT ACTUATORS

PARTS REFERENCE

Ref. No.	Part Name	Computer Abbrev.	Ref. No.	Part Name	Computer Abbrev.	Ref. No.	Part Name	Computer Abbrev.
*15	Gasket (packing box)	GASKET	*32	Packing	PACKING	45	Cap Screw (diaph. case)	CAP SCR
17	Yoke	YOKE	33	Spring Seat (upper)	USPR ST	46	Nut (diaph. case)	NUT
18	Cap Screw (L. case to yoke)	CAP SCR	34	Spring Seat (lower)	LSPR ST	56	Travel Indicator Scale	T I SCL
*19	Gasket (L. case to yoke)	GASKET	35	Pipe Plug	PIP PLG	57	Machine Screw	MCN SCR
20	Packing Nut	PKG NUT	36	Spring Adjustor	SPR ADJ	70	Ball and Retainer	BAL & RTN
21	Snap Ring	SNP RING	37	Bushing (spring adjustor)	BUSHING	71	Spring Barrel	SPR BRL
22	Actuator Spring	ACT SPR	*39	Diaphragm	DIAPHRM	72	Spring Barrel Cap	SBL CAP
22A	Actuator Spring	ACT SPR	40	Diaphragm Plate	DPH PLT	73	Ball Bearing Race	BBG RCE
26	Actuator Stem	ACT STM	41	Diaphragm Washer	DPH WSH	74	Cap Screw (SBL to U D CSE)	CAP SCR
30	Nut (actuator stem)	NUT	43	Upper Diaphragm Case	U D CSE			
31	Packing Box	PKG BOX	44	Lower Diaphragm Case	L D CSE			

*Recommended spare parts.

Valve Sizes 2", 3", 4", 6" and 8"

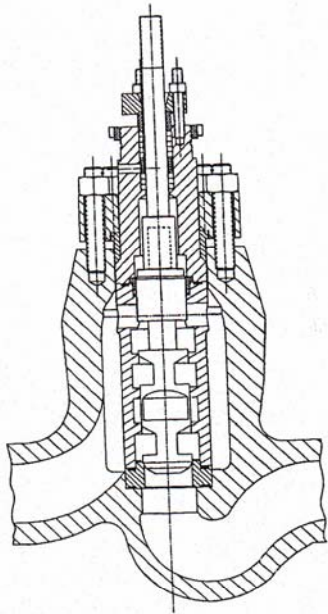

Cast Globe Body
Available in 2", 3", 4" 4 Stage

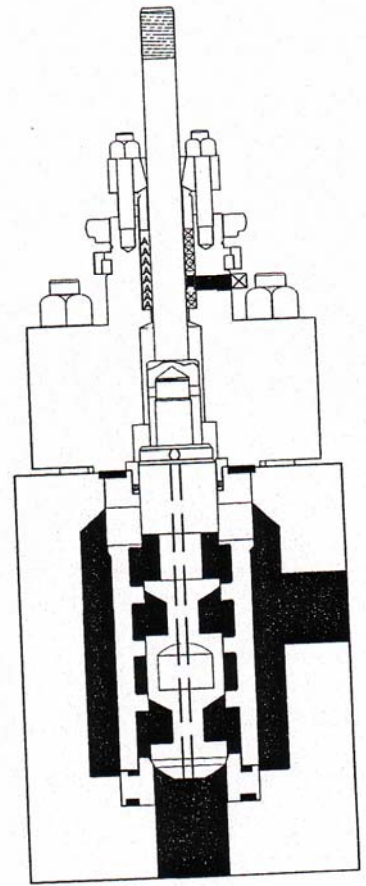

Forged Angle Body
2" Design

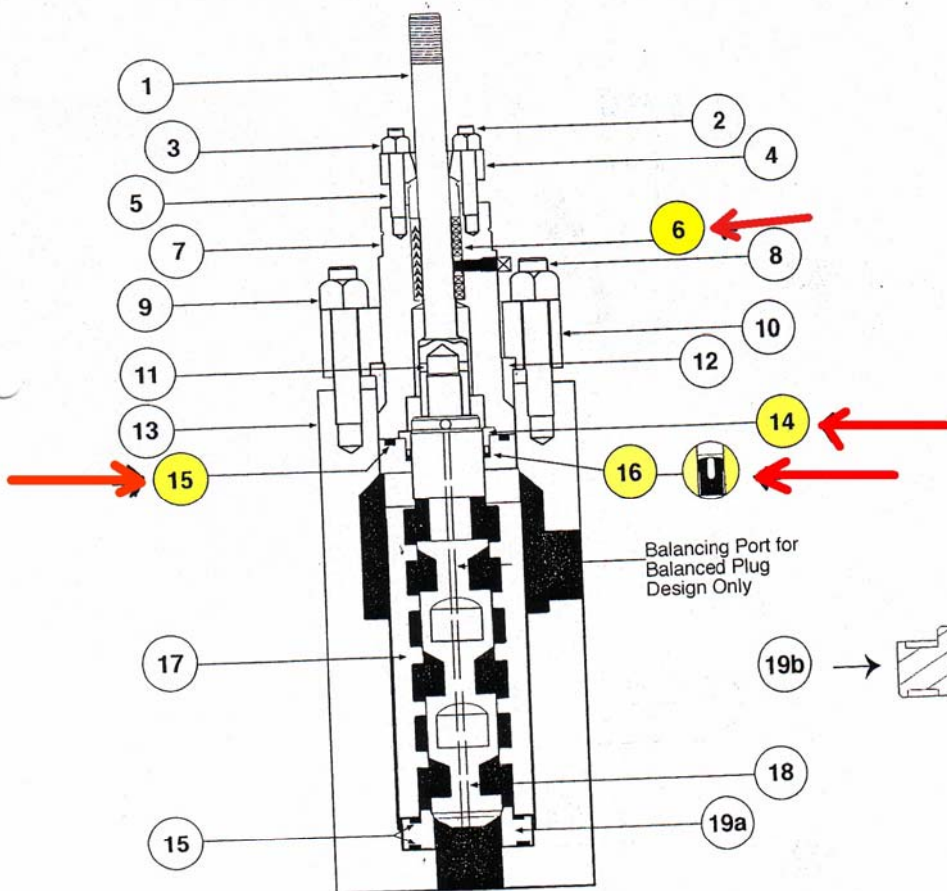

Forged Angle Body
3" through 8"



Soft Seat