

42-24-61-150

157

HCF HFF

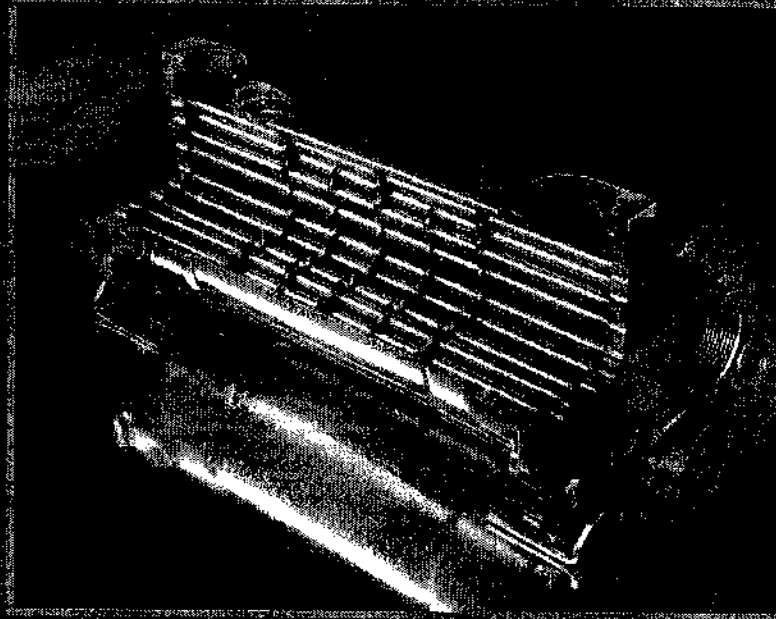

the basics of **HEAT TRANSFER**



ITT Industries
Engineered for life

THE BCF FAMILY

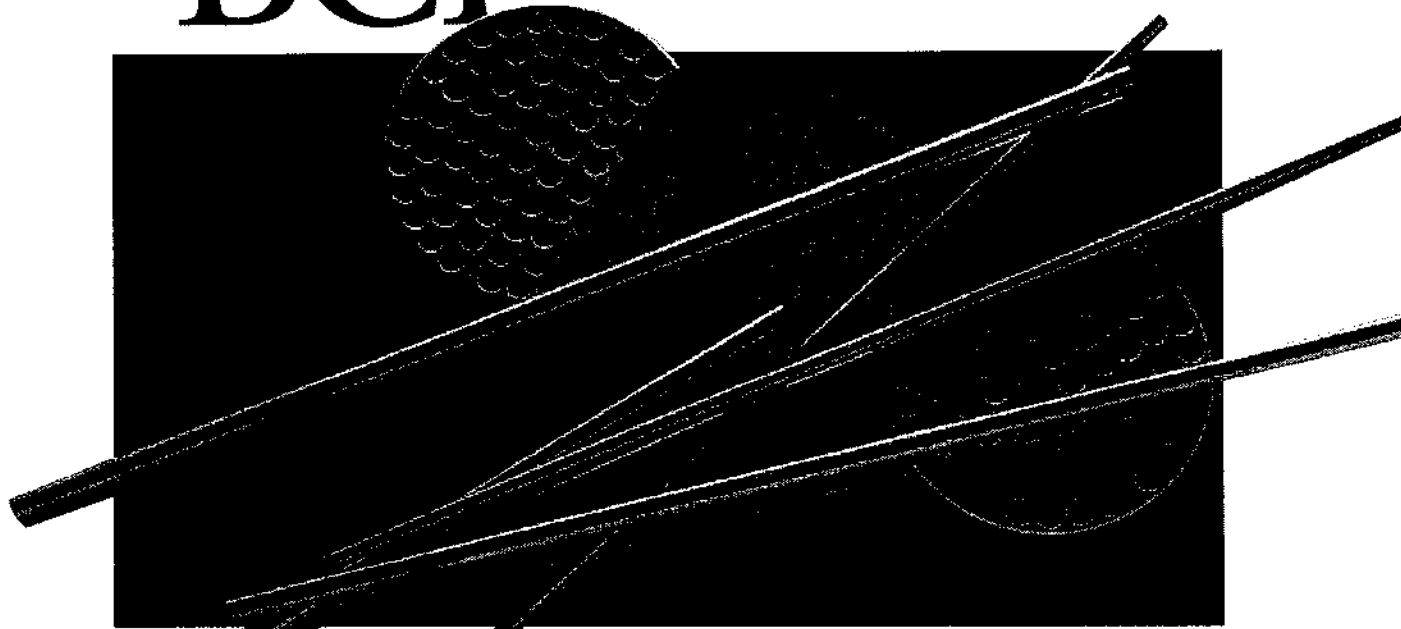

more than heat exchangers — the basics of heat transfer

There was a time when every heat exchanger was custom-designed for an application and built by hand. The BCF[®] changed that. It was the first unit totally pre-engineered, quality-made and carried in stock, ready for installation in modern industry. Today, fifty-plus years and more than a million units later, there are 110 standard BCF models available to meet your needs. And if one of these models doesn't suit your requirements, an HCF[®] or HFF[®] model, custom-assembled from basic BCF components, might be exactly what you're looking for.

The BCF family of heat exchangers can be found in virtually any industrial installation where stringent heat transfer requirements exist. Examples of popular applications include:

- ✦ Oil temperature control in hydraulic power units, plastic injection molding machines, gear reducers, etc.
- ✦ Oil, gas and water cooling in vacuum pumps, compressors, engines, and turbines
- ✦ Critical temperature control of fluids in process industries

Since introducing the BCF, we've continued to develop innovative solutions for process applications throughout industry. The latest computer design systems keep us up-to-date with cutting-edge heat transfer technology.

A comprehensive inventory of pre-engineered and stocked components ensures timely product delivery. And we're continually advancing thermal research with the support of our well-equipped research laboratory. Today, ITT Standard is a recognized leader in heat transfer products and technology, with the broadest product line available anywhere.

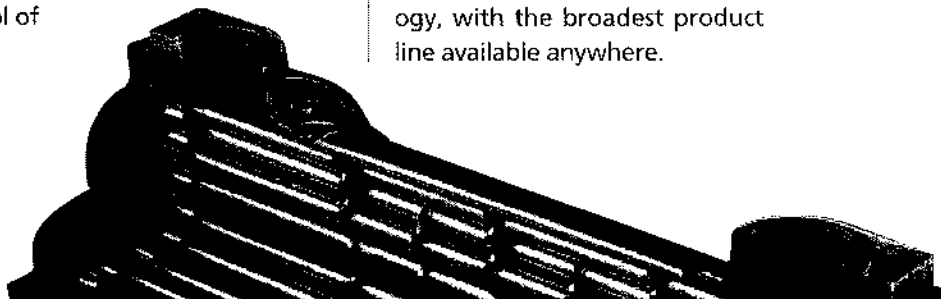

BCF[®]

STOCKED HEAT EXCHANGERS.



SINGLE-PASS
Series 02000, 03000, 04000, 05000, 06000, 08000



TWO-PASS
Series 03000, 04000, 05000, 06000, 08000



FOUR-PASS
Series 03000, 04000, 05000, 06000, 08000

SEE DETAILED INFORMATION ON PAGES 6 AND 7.

HCF[®]

VARIABLE DESIGN.

Options include special lengths, baffle spacing, tube sizes and materials, nozzle orientations, and bonnet materials, including heat exchangers with 90/10 copper/nickel tube side.



SINGLE-PASS
Series 02000, 03000, 04000, 05000, 06000, 08000



TWO-PASS
Series 03000, 04000, 05000, 06000, 08000



FOUR-PASS
Series 03000, 04000, 05000, 06000, 08000

SEE DETAILED INFORMATION ON PAGES 6 AND 7.

HFF[®]

HEAT EXCHANGERS WITH INTEGRAL SAE FLANGED CONNECTIONS.



FOUR-PASS
Series 05000, 06000, 08000. Also available in one- and two-pass models, as the HFF-K.

SEE DETAILED INFORMATION ON PAGES 6 AND 8.

BCF The First Pre-Engineered Heat Exchanger

BRASS HUBS:

Designed with large open areas under connections. Allows unrestricted flow into the heat exchanger tube bundle to lower entrance velocity and reduce pressure loss.

BRASS SHELL:

Tough, seamless and completely non-ferrous. Highly corrosion-resistant.

SMOOTH, STRAIGHT-THROUGH TUBES:

Easy to clean.

MOUNTING FOOT:

Designed for 90° rotation in either direction.

BRASS BAFFLES:

Direct flow through shell. Unique flanged lips provide more contact area for greater tube support, less internal bypass, and better heat transfer. Designed to minimize the possibility of vibration, prevent tube damage, and lengthen life.

MINIMUM CLEARANCES:

Designed to prevent bypassing and ineffective areas.

GASKETS:

Non-asbestos, compressed fiber.

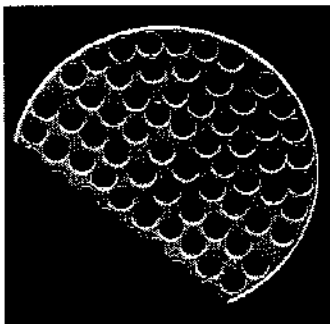



Adapting heat exchangers to machinery was once a time-consuming and costly engineering task for designers. Each heat exchanger had to be custom-designed for each job, and if replacement was necessary, equipment downtime was prolonged. ITT Standard changed all that with the BCF heat exchanger.

Today, the classic BCF design offers such advanced features as all brass shell side construction (non-ferrous) and non-asbestos, compressed fiber gasketing. In addition to providing **superior heat transfer performance**, the BCF is a high-pressure unit designed for 300 psi shell side and 150 psi tube side.

STRAIGHT, SEAMLESS COPPER TUBES:

Roller-expanded into the tubesheets for a leak-proof fit

CAST IRON BONNETS:

For rugged service at moderate cost.

CORROSION ARRESTERS:

Renewable zinc, with telltale indicator to prevent electrolytic damage.

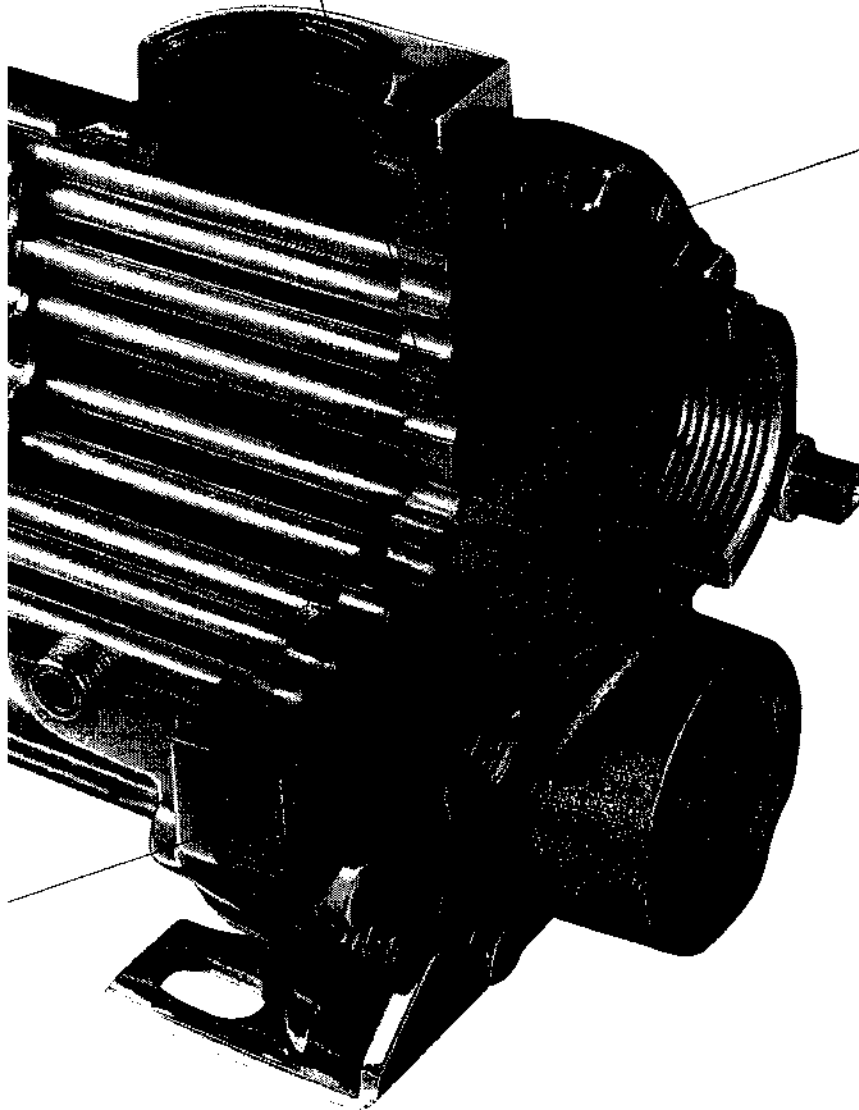

Dimension Drawings – Standard BCF and HCF Heat Exchangers

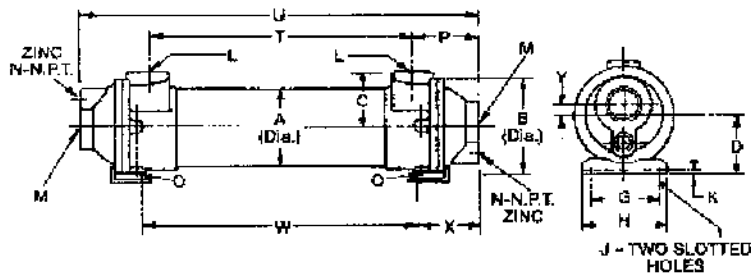

SINGLE-PASS
Series 02000, 03000, 04000, 05000, 06000, 08000

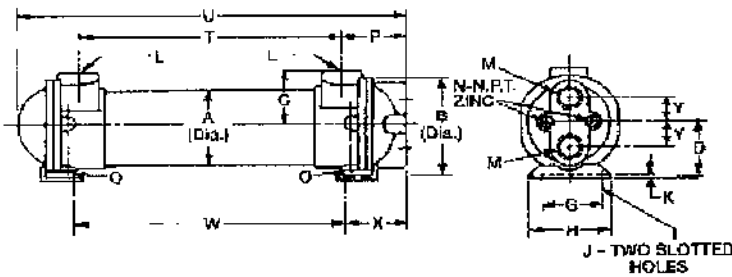

TWO-PASS
Series 03000, 04000, 05000, 08000

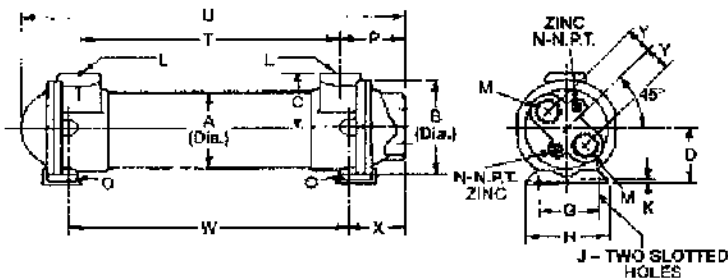

TWO-PASS
Series 06000

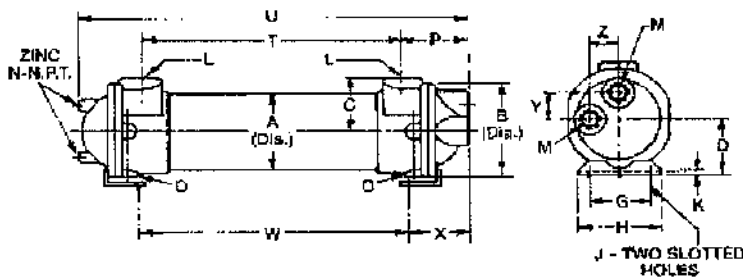

FOUR-PASS
Series 03000, 04000, 05000, 06000

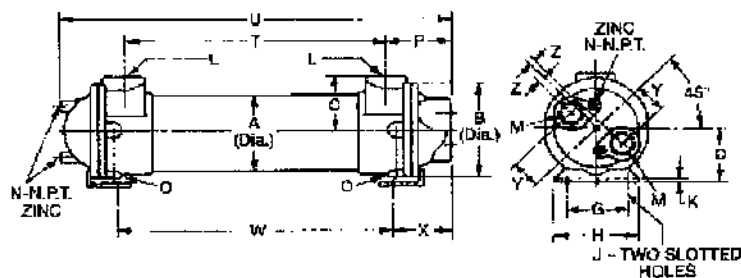

FOUR-PASS
Series 08000

All catalog dimensions are in inches unless otherwise noted and are subject to variation. Use only certified drawings for construction purposes. All connections are N.P.T.

For BCF ordering, see page 9.

Standard BCF and HCF Heat Exchangers

DESIGN TEMPERATURE AND PRESSURE

	Design Pressure		Test Pressure		Design Temperature	
	psi	kPa	psi	kPa	°F	°C
Shell side	300	2068	350	2413	300†	149†
Tube side	150	1034	225	1551	300	149

†For ASME Code construction, unit is designated as HCF-C, shell side design temperature is limited to 200°F (93°C) and design pressure is limited to 200 psi (1379 kPa)

UNIT	Shell Side	A	B	C	D	G	I	J	K	L	N	O	T	V	W
02008	1.2	2-1/8	2-3/8 sq	1-11/16	---	---	---	---	---	1	3/8	---	6-1/4	---	5
03008	2.4												6-1/8	7-5/8	12
03014	4.3	3-1/8	4-3/16	2-7/16	2 3/8	3-1/4	4	3/8 x 5/8	1/8	1	3/8	2-1/4"	12-1/8	13-5/8	14
03024	7.4												22-1/8	22-5/8	17
04014	8.3												11-1/8	12-7/8	37
04024	14.1	4-1/8	5-7/8	3-1/8	3 1/2	3-1/2	4-3/4	1/2 x 1-5/8	3/16	1-1/2	3/8	6-3/0"	21-1/8	22-7/8	45
04036	21.2												33-1/8	34-7/8	54
05014	9.1												11-1/8	11-3/4	45
05024	16	5-1/8	6-1/2	3-5/8	3-1/2	4	5	1/2 x 7/8	3/16	1-1/2	3/8	6-1/4"	21-1/8	21-3/4	55
05036	24												33-1/8	33-3/4	65
06024	23												20-1/2	21-1/2	75
06036	34	6-1/8	7-1/2	4-1/4	4-1/8	5	6	1/2 x 7/8	3/16	2	1/2	6-1/4"	32-1/2	33-1/2	95
06048	45												44-1/2	45-1/2	115
06060	56												56-1/2	57-1/2	135
08024	41												19	20-1/2	105
08036	62												31	32-1/2	185
08048	82	6-1/8	9-3/4	5-5/8	5-3/8	7	8-1/4	5/8 x 1-1/8	3/16	3	1/2	6-1/4"	43	44-1/2	220
08060	103												55	56 1/2	255
08072	124												67	68-1/2	290

†Indicates no. & size

UNIT	Shell Side	TWO-PASS ONLY						FOUR-PASS ONLY						W					
		M	P	U	X	Y	M	P	U	X	Y	M	P		U	X	Y	Z	
02008	1.2	3/4	2-3/8	11	---	3/8	---	---	---	---	---	---	---	---	---	---	---	---	5
03008	2.4																		12
03014	4.3	1-1/2	2-9/16	11-1/4	1-7/8	3/8	1	2-7/16	10-3/4	1-3/4	1	3/4	2-5/16	16-7/8	1-5/8	i	i	14	
03024	7.4			17-1/4					16-3/4					26-7/8					17
04014	8.3			27-1/4					26-3/4					17-5/8					37
04024	14.1	2	3-7/16	18	2-9/16	1/2	1-1/4	3-7/16	17-5/8	2-9/16	1-3/16	3/4	3-7/16	27-5/8	2-9/16	1-1/16	1-1/16	45	
04036	21.2			40					39-5/8					39-5/8					54
05014	9.1			18-1/2					18-5/16					18-3/8					45
05024	16	2-1/2	3-11/16	28-1/2	3-3/8	---	1-1/2	3-11/16	28-5/16	3-3/8	1-1/2	1	3 9/16	28-3/8	3-1/4	1 11/16	1 11/16	55	
05036	24			40-1/2					40-5/16					40-3/8					65
06024	23			29					28-3/4					29					75
06036	34	3	4-1/4	41	3-3/4	---	2	4-1/4	40-3/4	3-3/4	1-9/16	1-1/2	4-1/4	41	3-3/4	2	2	95	
06048	45			53					52-3/4					53					115
06060	56			65					64-3/4					65					135
08024	41			31					30-1/2					30-3/4					105
08036	62			43					42-1/2					42-3/4					185
08048	82	3	6	55	5-1/4	---	2-1/2	6	54-1/2	5-1/4	2-1/4	2	6	54-3/4	5-1/4	2-5/8	11/16	220	
08060	103			67					66-1/2					66-3/4					255
08072	124			79					78-1/2					78-3/4					290

NOTE: These dimensions will also apply to the HCF design where standard BCF components are used.

Dimension Drawings – Standard Four-Pass HFF SAE Flanged Heat Exchangers

DIMENSION DRAWINGS

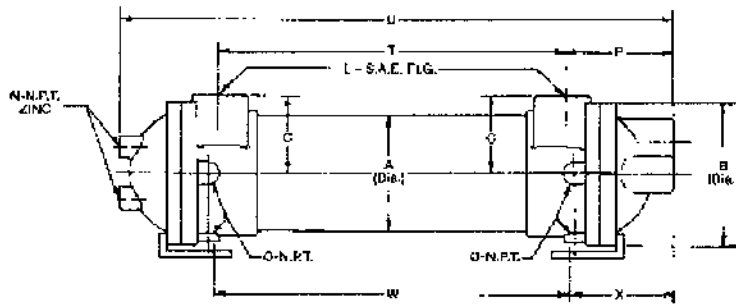

SERIES 05000 AND 06000 FOUR-PASS

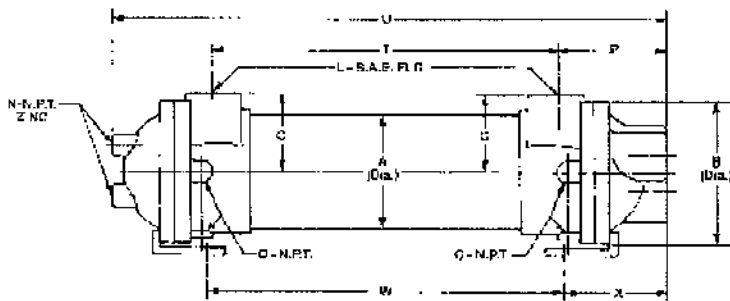
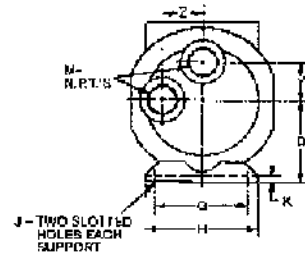

SERIES 08000 FOUR-PASS

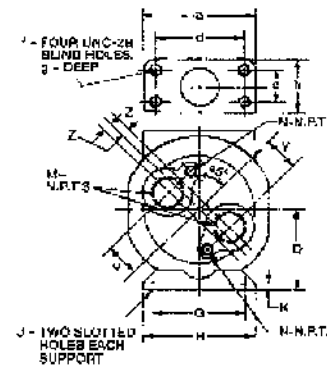

DESIGN TEMPERATURES AND PRESSURES

	Design Pressure		Test Pressure		Design Temperature	
	psi	kPa	psi	kPa	°F	°C
Shell side	300	2068	350	2413	300	149
Tube side	150	1034	225	1551	300	149

Std.	Shell	A	B	C	D	E	F	G	H	I	J	K	L	M	N	O	P	Q	R	T	U	W	X	Y	Z	V	S	Wt.					
05014	9																			11	13-3/8	11-2/4											
05024	16	5-1/8	0-1/2	4-1/4	3-1/2	4	5	1/2x7/8	3/16	1-1/2	1	28	6-1/4"	3/8					21	29-3/8	21-3/4	3-1/4	1-11/16	1-11/16	3-11/16	2-1/2	2-3/4	1-13/32	1/2	3/4	55		
05036	24																		23	41-3/8	23-3/4												
05048	32																		35	52-3/8	45-3/4												
06024	23																		20-1/2	29	21-1/2												
06036	34																		32-1/2	41	33-1/2												
06048	45	6-1/8	7-1/2	4-3/4	4-1/8	5	6	1/2x7/8	3/16	2	1-1/2	1/2	8-1/4"	4-1/4					44-1/2	33	45-1/2	3-3/4	2	2	4	3	3-1/8	1-1/4	1-2	3/4	116		
06060	56																		56-1/2	63	57-1/2												
06072	67																		63-1/2	77	69-1/2												
08024	41																		19	30-3/4	20-1/2												
08036	52																		31	42-3/4	32-1/2												
08048	82	5-1/8	9-3/4	5-3/4	5-3/8	7	8-1/4	5/8x1-1/8	3/16	3	2	1/2	6-1/4"	6					43	54-3/4	44-1/2	5-1/4	2-3/8	1-1/16	5-5/16	4-3/16	4-3/16	2-7/16	5/8	15/16	230		
08060	103																		55	66-3/4	56-1/2												
08072	124																		67	78-3/4	66-1/2												

Designated as HFF-S units, the following options are available:
Shell Side – 05600 Series – 1 1/4" SAE Flanged Connection
06600 Series – 1 1/2" SAE Flanged Connection

Shell Side – 08000 Series – 2" SAE Flanged Connection
Tube Side – One and two pass with BCF connections

*Indicates no. & size

Options

Options and special models, based on proven BCF designs, can be assembled to fit almost any requirement. Application of the BCF family is limited only by your imagination.

- **HCF** – Fixed tubesheet model offers special materials, tube sizes, tube lengths, nozzle orientations, ASME Code construction (HCF-C), and many other custom features. It is also available in 90/10 Cu Ni tube side, offering rugged, dependable service for salt and brackish water applications in marine environments.
- **HFF** – Fixed tubesheet oil cooler fitted with 4-bolt SAE flanged connections for application in hydraulic systems.

- **TCF** – Available in fixed tubesheet or U tube style, with plate fin enhanced surface on the shell side for ultra-compact selections in oil cooling service.
- **SSCF** – The stainless steel version of the BCF coolers, used in many chemical process applications when copper alloys are unsuitable. For more details, request Bulletin 104-24.
- **BCP** – Removable bundle, packed floating tubesheet model offers thermal expansion capability in a straight tube design in one or two passes.
- **BCU** – U-tube cooler (two or four-pass), removable bundle design combines the greatest thermal expansion capability with economical construction.

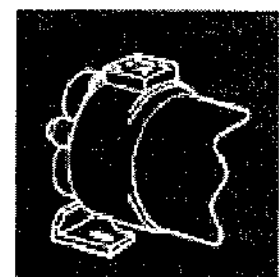
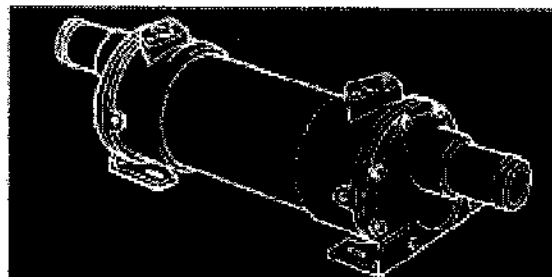
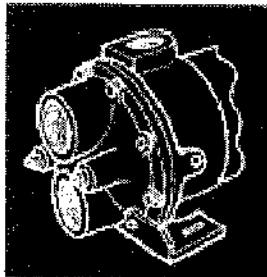

Ordering instructions for BCF heat exchangers

1. Specify size designation

BCF Q3 Q14

 (a) (b)

- (a) First two digits indicate shell diameter.
 (b) Next three digits indicate tube length, in inches.

2. After size designation, indicate a dash followed by three digits, which identify the number of passes on tube side and baffle spacing on shell side (see table below).

BAFFLE SPACING	ONE-PASS	TWO-PASS	FOUR-PASS
O*	001	002	005
W*	003	004	006

Example: BCF 03014-005

This is a 3" nominal diameter heat exchanger with a 14" tube length, O* baffle spacing and four-pass tube side.

O* baffle spacing is most commonly used when shell side flow rate and/or heat transfer coefficient is low.

W* baffle spacing is most commonly used when shell side flow rate and/or heat transfer coefficient is high.

For the most efficient and economical heat exchanger selection, contact your local ITT Standard distributor, listed at www.ITTSTANDARD.com.

* This information applies only to BCF exchangers; it does not apply to H-CU design.

Models of efficiency.

Engineered/customized
heat exchangers
for process and other
heating/cooling
applications.

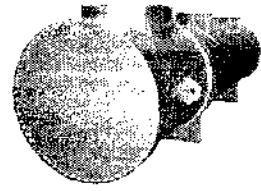

Plateflow®
plate-and-frame
exchangers.



Pre-engineered
shell-and-tube heat
exchangers for general
heating and cooling.

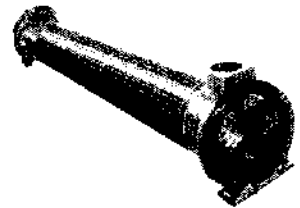

Heat transfer coils.

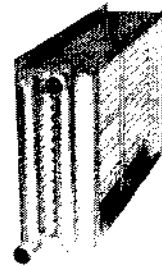

FanEx® and AirEx® air/oil,
air/air, or air/water
heat exchangers.



For more information, please contact:

Lit #104-73

© 2005 ITT Standard

920243.10M.12-05

 Printed on recycled paper.



ITT Standard

ITT Industries

Engineered for life

175 Standard Parkway • Cheektowaga, NY 14227

800/447-7700 Fax: 716/897-1777

www.ittstandard.com

Formerly **AMERICAN-STANDARD™** HEAT TRANSFER DIVISION